

WLED Range Extender V0.4

Art. No. 90065 + 90066



- Developed for extending the data signal of single-wire addressable LEDs (e.g. NeoPixel)
- Designed for controlling 5V, 12V and 24V LEDs: WS2812(B), WS2813, SK6812, etc.
- Integrated fuse with signalling LED and capacitor in the output module (fused capacitor board)
- Use between controller and LED strip or between two sections.
- Range up to 500m, theoretical maximum 1200m
- +/- 15kV ESD protection



Functionality

The cod.m WLED Range Extender converts the 800kHz signal from the WLED Controller into a signal on a differential pair (RS-485) so that the usual data cable length of two metres can be exceeded.

With the range extender, cable lengths of up to 500 metres are possible on a twisted pair cable (network cable, JY-ST-Y, "bell wire").

A fused capacitor board is also integrated in the WLED Range Extender OUT module. This means that only one board is required at the start of the LED strip.

As each LED on a digital strip generates a new data signal, the range extender can also be used to extend the data signal between two LED strips.

In addition, several OUT modules can be supplied with one IN module of the range extender. This allows the WLED signal to be multiplied.

Connections WLED Range Extender IN module

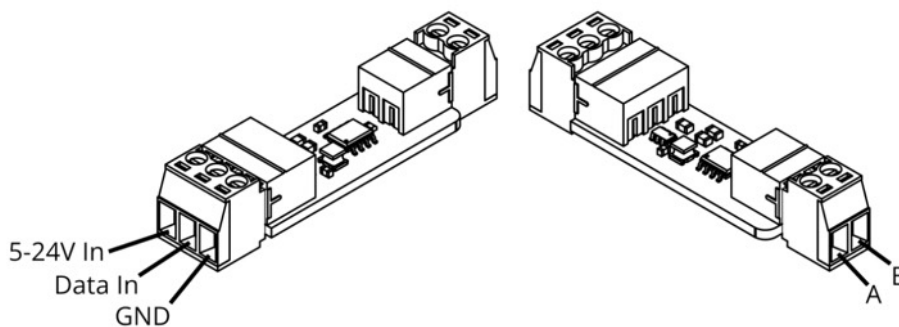

Connections WLED Range Extender OUT module

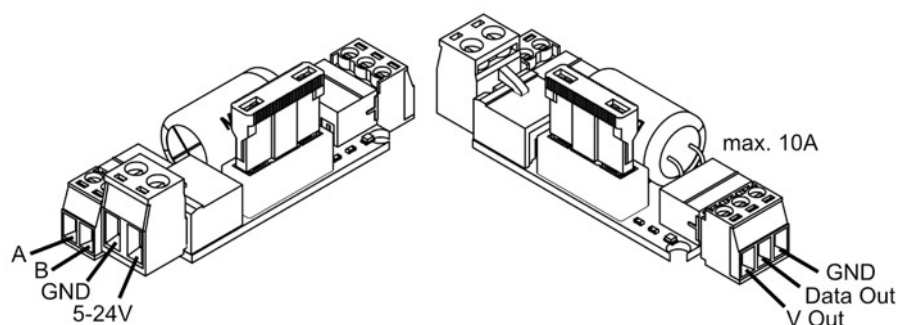

Commissioning

1. When switched off, wire the controller and the range extender IN module according to the wiring diagram. The IN module can be supplied with 5-24V.
2. Connect the range extenders (A/B) using twisted pair (twisted wire pair). Ensure that A/B is not reversed. Ideally, connect a shield in accordance with DIN EN 60204-1; unshielded is also possible for short distances.
3. Connect the power supply to the OUT module. Select the cable cross-section according to the power of the connected strip - load with a maximum of 10A. If there are several power feeds, use additional fused capacitor boards (item no.: 90062) and dimension the fuses proportionally to the total power. See also the WLED Fused Capacitor Board instructions.
4. Switch on the power supply, configure and use the controller according to the instructions.
5. The WLED range extenders require no further configuration.



⚡ Attention!

JST-SM connectors can be loaded with a maximum of 3A. Connect additional cables or avoid JST-SM connectors completely .

Terminating resistors

In difficult environments, with poor line quality or over very long distances, poor data transmission and the resulting interference at the signal output can occur.

To eliminate faults, always check the twisted pair cable and, if necessary, connect the 120Ω terminating resistor to both modules using a solder jumper. This slightly increases the power consumption of the WLED range extender.

Intended use

The modules are intended for extending the data cable of single-wire pixel strips. Only the specified intended use is permitted. Any other use will invalidate the warranty and liability.

Safety instructions

Keep the modules away from heat and sunlight. Avoid contact with dust and the influence of liquids. Only use the modules indoors. Protect the modules from electrostatic discharge.

Technical data

Short description:	cod.m WLED Range Extender V0.4 90067 consisting of 90065 and 90066	Dimension:	IN: 55 x 14 x 10mm (incl. plug) OUT: 67 x 23 x 23mm (incl. plug)
Supply voltage:	5-24V, <0.2W / pair	Weight:	IN 6g (incl. plug) OUT 20g (incl. plug)
Ambient temperature:	+5 to +45°C	Standard:	EIA-485-A-98

Open source project (CC-BY-NC-SA): Support via shop@codm.de, no telephone support!

cod.m GmbH
Allendorfer Straße 56
35708 Haiger

+49 2773 91878-0
<https://www.codm.de>
<https://shop.codm.de>

Managing Director: Patrik Mayer
Wetzlar Local Court, HRB 6686

UST-ID: DE815516311
WEEE-Reg.-No.: DE78677954

cod.m



RoHS

